

# INSTALLATION MANUAL

62116F

ecolight



80 CRI

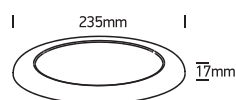

one  
LIGHT

230V | SMD 2835 | 16W | IP20 | Plastic

Complete with 210mA driver.

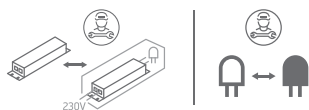
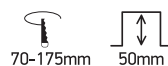

## SURFACE INSTALLATION:

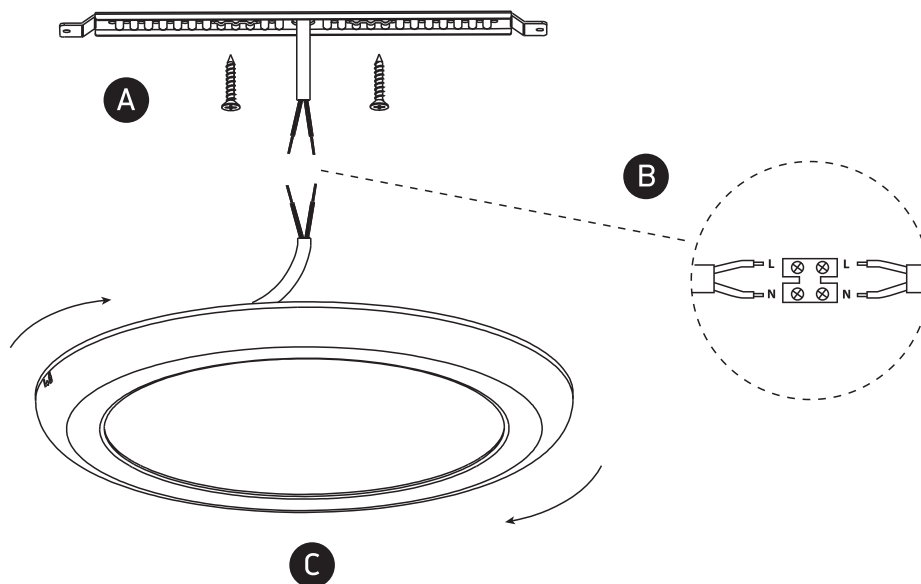

## RECESSED INSTALLATION:

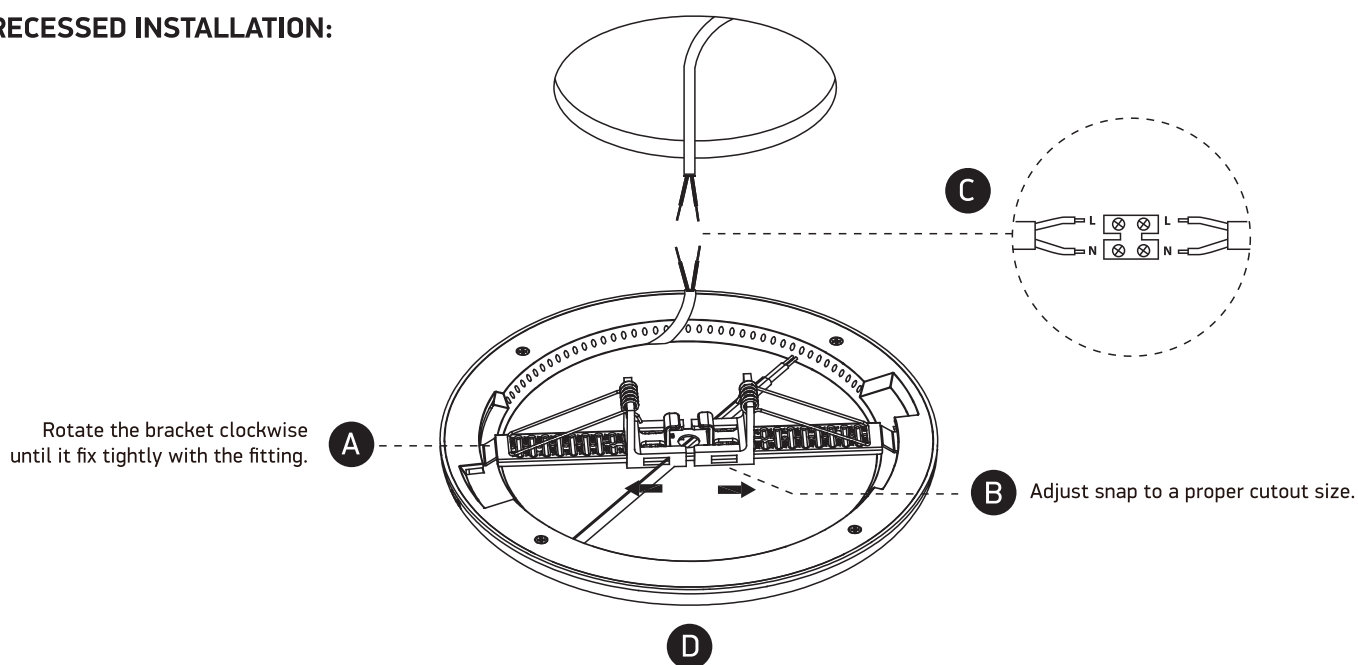

## Warnings:

1. Make sure that the product is installed properly before connecting to electricity.
2. Do not cover the fitting.
3. Maintenance and installation should only be carried out by a professional electrician.