

EMERGENCY LIGHT 89406R



TECHNICAL SPECIFICATION

- Supply voltage: 220 - 240VAC/50 - 60Hz, 176 - 275VDC, 24VDC
- Insulation class: II
- Protection level: IP44
- Time of operation in emergency mode: 1, 2 or 3h
- Light source: 1W
- Battery charging time: up to 24h
- Ambient temperature : 0 - +40°C
- Viewing distance: 25m

MAIN FEATURES:

- Battery charging indication by LED
- Electronic protection against total battery discharge
- Self-test function (optional)
- Operation in emergency or mains and emergency mode available
- Using to Rubic system available
- Using to central battery available
- Surface assembly (wall, ceiling)
- Assembly indoors to flat surface
- Polycarbonate body, plexi glass
- The luminaire can be powered maintained or non maintained
- Controlgear supplied within this luminaire performs the function of changeover operation from normal to emergency mode

RECOMMENDATIONS FOR USE:

The following rules must be observed to ensure the correct and reliable operation of the fitting:

- Battery packs must be compatible with emergency modules
- Installation of fitting should be made by appropriate person which is authorized for such works
- After installation of fitting, the formatting of battery must be made while continuous charging for a period of 24 hours and fully discharging it through lighting
- Three full formatting cycles must be performed to achieve maximum battery capacity
- Technical inspection of the fitting and, in particular, of the battery must be performed once a year
- It is important to maintain temperature parameters for battery packs, i.e. from 0°C to + 55°C
- It is forbidden to make any changes in electronic system design
- If the fitting does not withstand its rated operation time, the battery must be renewed
- It is recommended by the manufacturer to renew the battery every 4 years
- The fitting is equipped with a replaceable light source
- Rated luminous flux in emergency mode amounts to 100%

TERMS AND CONDITIONS OF WARRANTY:

The condition to acknowledge the warranty is:

- No mechanical damage
- No evidence of changes made by third party in fitting design and, in particular, emergency module
- Proper use, as recommended
- Proper connection of supply voltage and battery pack (attention must be paid to the polarity of the battery and converter terminals).

TESTING THE FITTING:

It is possible to test the fitting using test button placed in the housing (option).

At the time when the supply voltage is connected to the fitting, the green LED lights up indicating the emergence of voltage in the electronic system and thus the battery charging. By pressing the button, the test of fitting is activated through an open circuit, and by this the decay of mains voltage is simulated and the switching over by electronic system to the emergency operation mode is caused. During emergency operation, the LED is no longer lit, the fitting is powered from the battery. When the button is released, the mains voltage returns and the fitting is operated in mains mode, charging process is started.

AUTOTEST FUNCTION:

Test A is run automatically every 28 days. During test A a conversion kit is switched to emergency mode for 1 minute and the following parameters are checked: control of battery power discharge, control of battery. Test B is run automatically every 364 days. During test B a conversion kit is switched to emergency mode for all duration time and the following parameters are checked: control of battery power discharge, control of minimum battery voltage.

1. 89406R FITTING

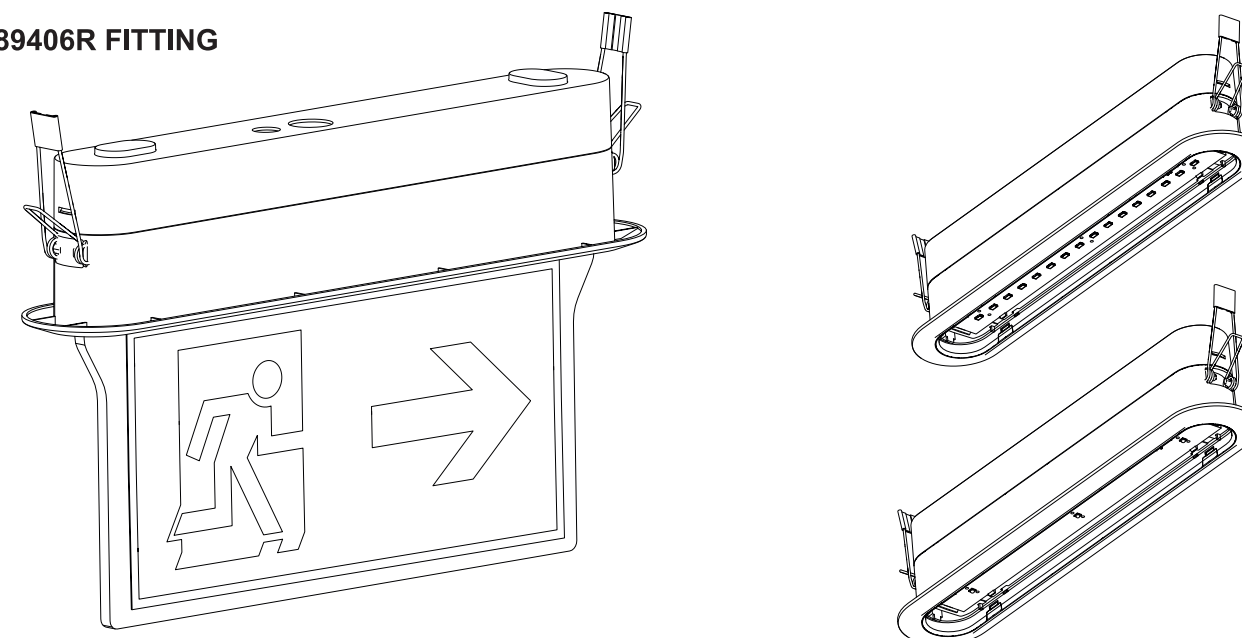

2. 89406 DISASSEMBLING

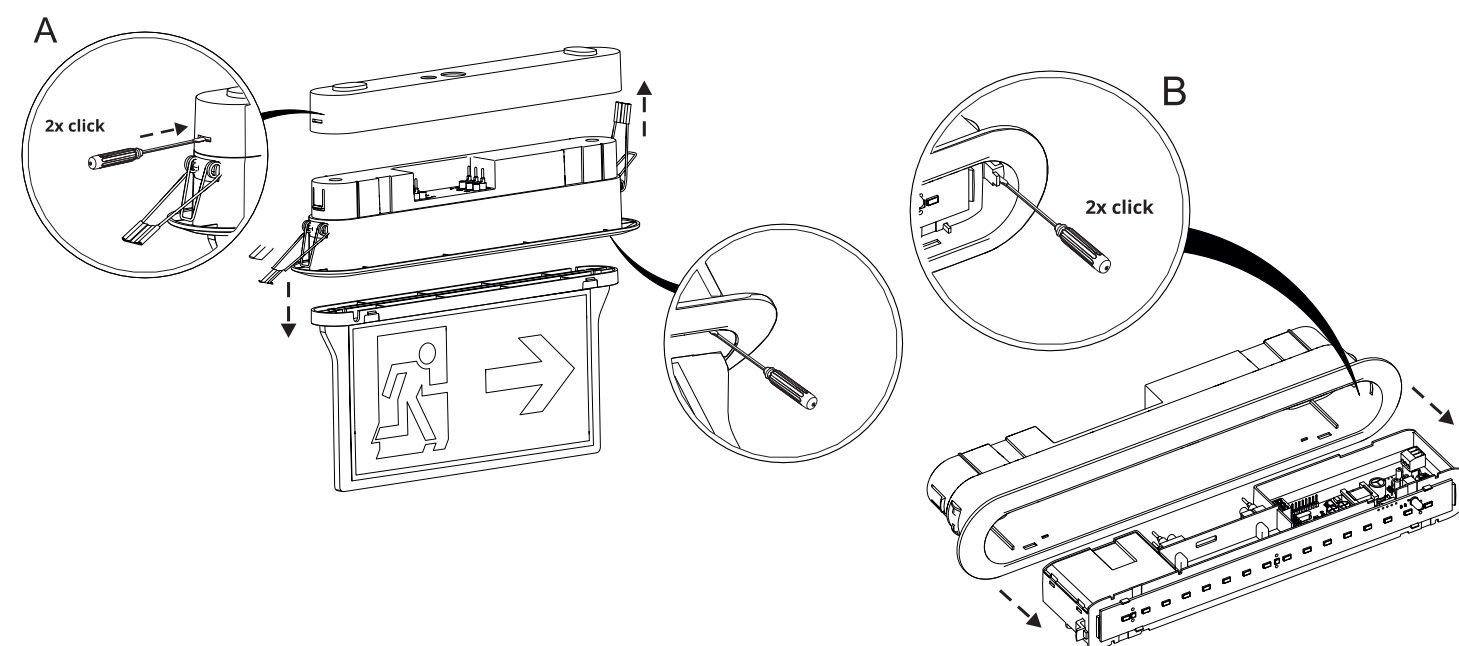

3. GUIDELINES

- in a fitting the cable L and L1 is required to the maintained mode (SA), the non maintained mode (SE) does not require L1 cable
- during the battery connection, pay attention to proper polarisation „+“ and „-“
- during the communication cables connection, pay attention to isolation of the cable's shield which can lead to a short circuit of the others communication lines
- The first if all you have to connect battery to inverter and then connect the mains supply
- CBS fitting address cannot be doubled in a single circuit
- during connection to the FZLV system, keep the proper polarisation „+“ , „-“
- the drawing enclosed in this instruction may vary than in the finished products, to a proper connection follow the instruction enclosed in the label attached on a fitting

LP	Color of LED indicator shining	Light source	Description
1		any	Confirmation of the reset of timer or errors (AT)
2		shining	Emergency mode
3		not shining	Standby mode
4		any	Communication error (only RS)
5		any	Battery error
6		any	Light source or electronics error
7		shining	Performing test or mains mode
8		any	No battery
9		not shining	Battery loading
10		not shining	Standby mode (battery full)
11		not shining	Too much output power for this battery capacity
			Red indicator
			Green indicator

4. CONNECTION OF AUTONOMOUS FITTING

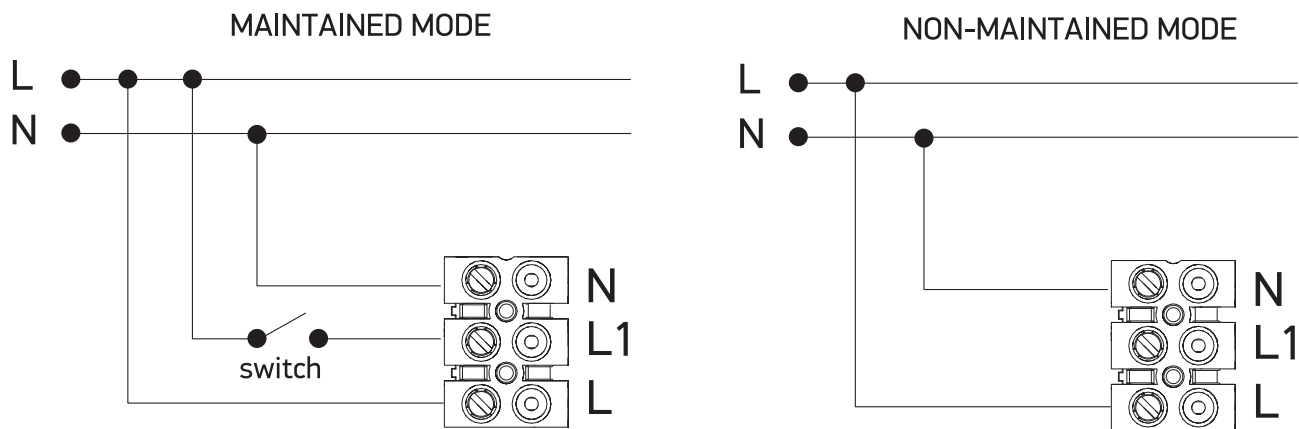
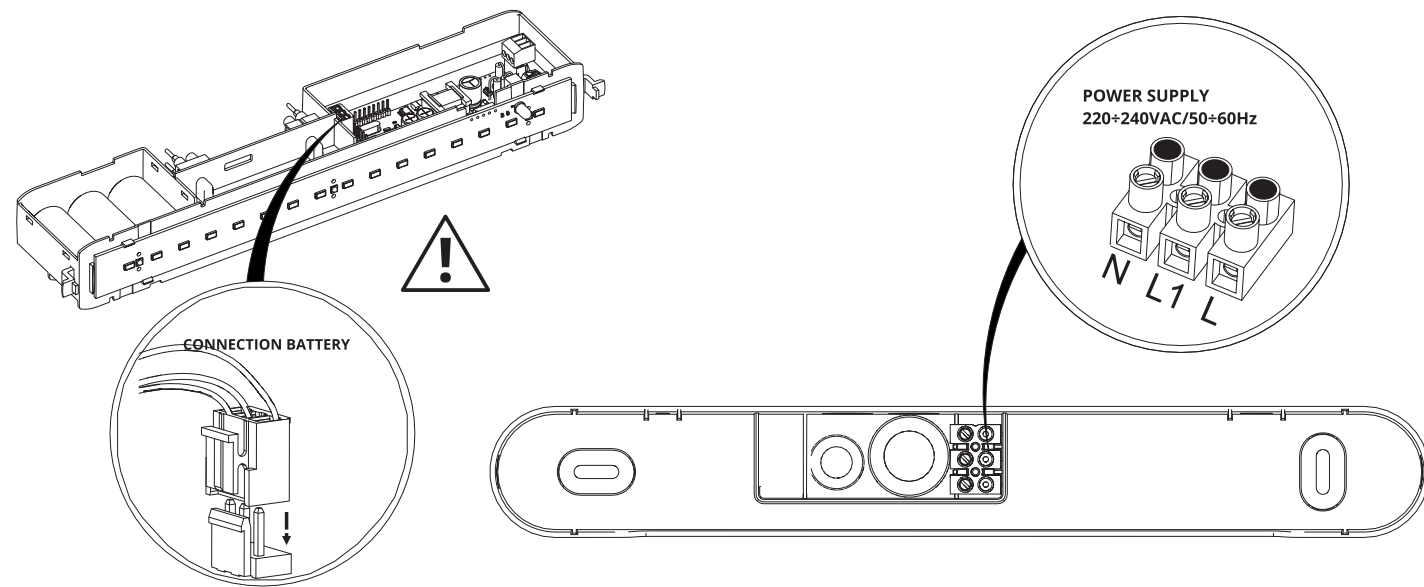

4b. CONNECTION OF FITTING TO FZLV CENTRAL BATTERY

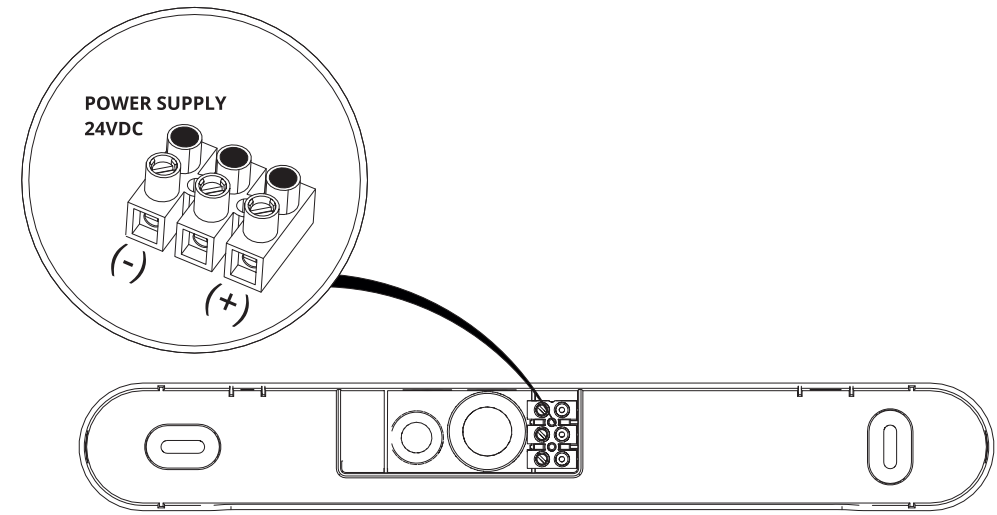

4c. CONNECTION OF FITTING TO RUBIC SYSTEM

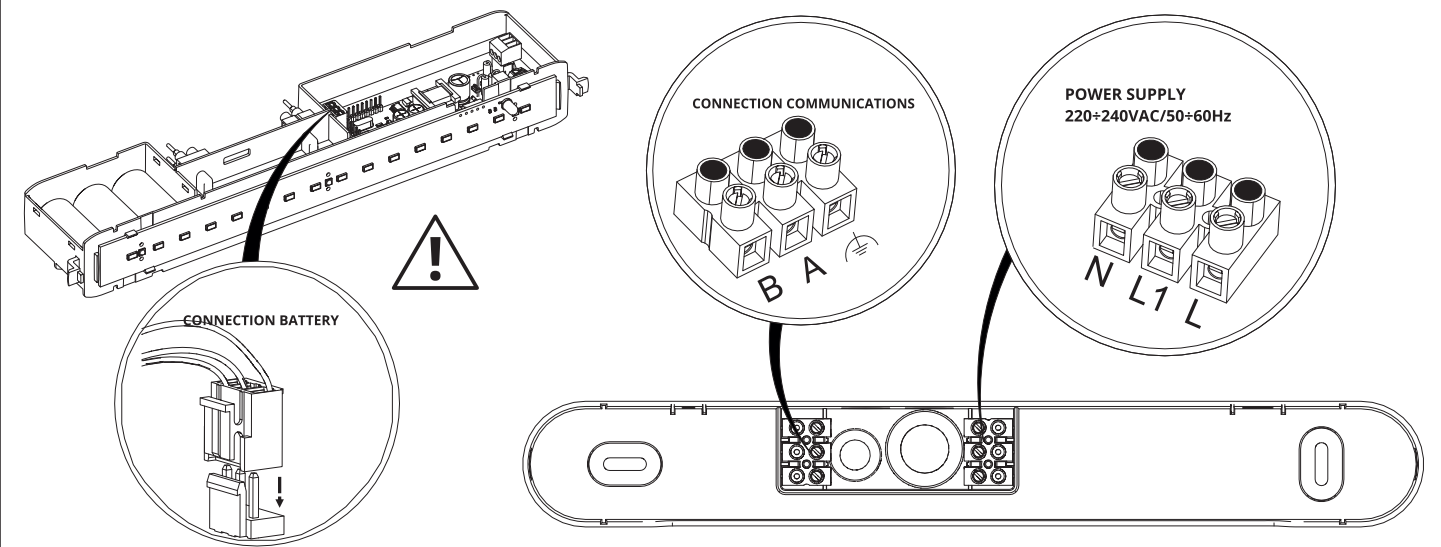

4a. CONNECTION AND SETUP OF FITTING TO CENTRAL BATTERY

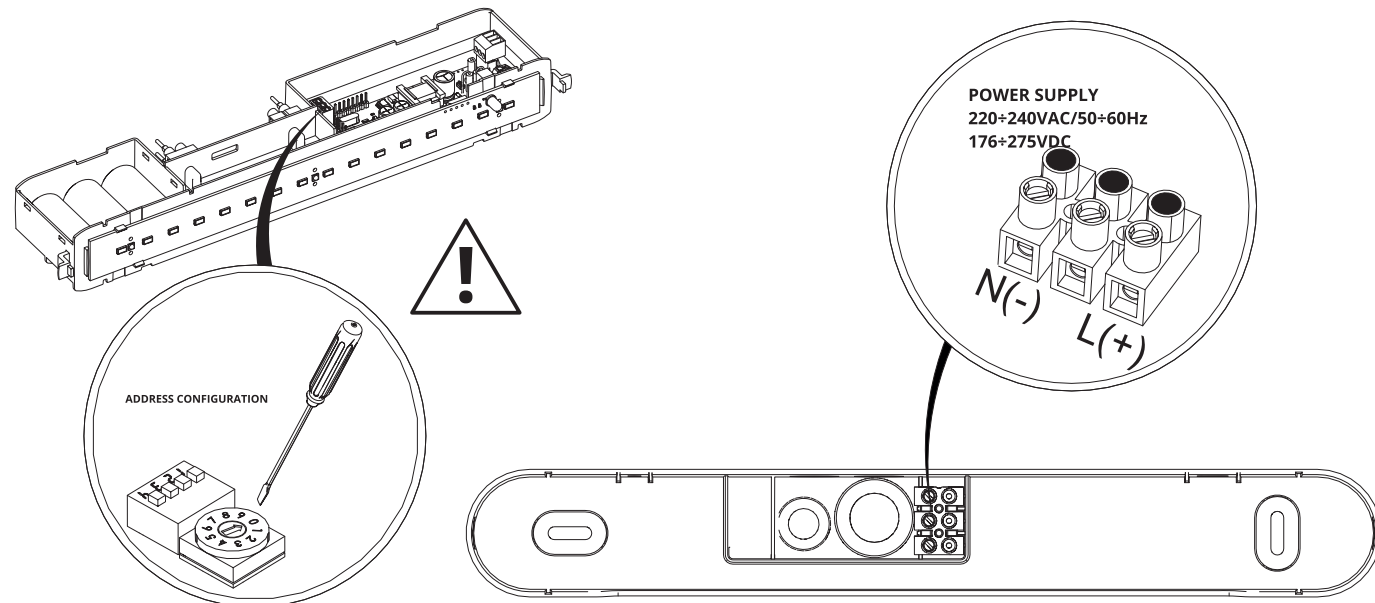

5. SURFACE ASSEMBLY

